

ROWAN

JESSICA

by Linda Whaley

ZB196-00011





JESSICA

by Linda Whaley



YARN

To fit age

0-3	3-6	6-9	9-12	12-18	2	months
						years

Summerlite 4ply

Cardigan with contrast trim

A Duck Egg 419

1 2 2 2 2 3 x 50gm

B P'e White 417

1 1 1 1 1 1 x 50gm

Plain cardigan

1 2 2 2 2 3 x 50gm

(photographed in Pure White 417)

**More Yarn
Information**

on knitrowan.com

NEEDLES

1 pair 2¼mm (no 13) (US 1) needles

1 pair 3mm (no 11) (US 2/3) needles

BUTTONS

4 [4: 5: 5: 6: 6] x buttons (10mm).

TENSION

28 sts and 36 rows to 10 cm measured over patt using 3mm (US 2/3) needles.

Pattern note: When working patt from chart, take care to ensure each dec of patt is matched by an inc. If there are insufficient sts to work both, work end sts of rows in st st.

Plain cardigan

Work as given for cardigan with contrast trim (below) but using same shade throughout.

Cardigan with contrast trim

BACK

Using 2¼mm (US 1) needles and yarn B work picot cast-on as folls: cast on 5 sts, cast off 2 sts, slip st on right needle back onto left needle, *cast on 4 sts, cast off 2 sts, slip st on right needle back onto left needle, rep from * until there are 67 [71: 73: 77: 79: 81] sts on left needle, cast on 2 sts. 69 [73: 75: 79: 81: 83] sts.

Break off yarn B and join in yarn A.

Row 1 (RS): Knit.

Change to 3mm (US 2/3) needles.

Work in g st for a further 3 rows, ending with RS facing for next row.

Beg and ending rows as indicated and repeating the 20 row patt repeat throughout, cont in patt from chart as folls:

Dec 1 st at each end of 7th [7th: 9th: 11th: 11th: 15th] and 3 [2: 1: 1: 3: 3] foll 4th [6th: 8th: 10th: 10th: 12th] rows, then on – [1: 2: 2: -: -] foll – [4th: 6th: 8th: -: -] rows.

61 [65: 67: 71: 73: 75] sts.

Work 5 rows, ending with RS facing for next row. (Back should meas

approx 8 [9.5: 11: 13: 14.5: 17] cm.)

Shape raglan armholes

Keeping patt correct, cast off 3 sts at beg of next 2 rows. 55 [59: 61: 65: 67: 69] sts.

Next row (RS): K3, K2tog, patt to last 5 sts, sl 1, K1, psso, K3.

Next row: P2, P2tog tbl, P to last 4 sts, P2tog, P2.

Rep last 2 rows 3 [2: 2: 2: 2: 2] times more.

39 [47: 49: 53: 55: 57] sts.

Next row (RS): K3, K2tog, patt to last 5 sts, sl 1, K1, psso, K3.

Next row: Purl.

Next row: K2, K2tog, patt to last 4 sts, sl 1, K1, psso, K2.

Next row: Purl.

Rep last 4 rows 3 [4: 4: 5: 5: 6] times more, then first 0 [0: 2: 0: 2: 0] of these rows again, ending with RS facing for next row.

23 [27: 27: 29: 29: 29] sts.

Break yarn and leave sts on a holder (for neckband).

LEFT FRONT

Using 2¼mm (US 1) needles and yarn B work picot cast-on as folls: cast on 5 sts, cast off 2 sts, slip st on right needle back onto left needle, *cast on 4 sts, cast off 2 sts, slip st on right needle back onto left needle, rep from * until there are 35 [37: 39: 41: 41: 43] sts on left needle, cast on 2 sts. 37 [39: 41: 43: 43: 45] sts.

Break off yarn B and join in yarn A.

Row 1 (RS): K to end, dec 0 [0: 1: 1: 0: 1] st at centre of row. 37 [39: 40: 42: 43: 44] sts.

Change to 3mm (US 2/3) needles.

Work in g st for a further 3 rows, ending with RS facing for next row.** Beg and ending rows as indicated and repeating the 20 row patt repeat throughout, now place patt from chart as folls:

Row 1 (RS): Work first 32 [34: 35: 37: 38: 39] sts as row 1 of chart, K5.

Row 2: K3, P2, work rem 32 [34: 35: 37: 38: 39] sts as row 2 of chart.

These 2 rows set the sts – front opening edge 3 sts in g st, next 2 sts in st st and rem sts in patt from chart.

Keeping sts correct as now set throughout, cont as folls:

Dec 1 st at beg of 5th [5th: 7th: 9th: 9th: 13th] and 3 [2: 1: 1: 3: 3] foll 4th [6th: 8th: 10th: 10th: 12th] rows, then on – [1: 2: 2: -: -] foll – [4th: 6th: 8th: -: -] rows. 33 [35: 36: 38: 39: 40] sts.

Work 5 rows, ending with RS facing for next row.

Shape raglan armhole

Keeping patt correct, cast off 3 sts at beg of next row. 30 [32: 33: 35: 36: 37] sts.

Work 1 row.

Next row (RS): K3, K2tog, patt to end.

Next row: Patt to last 4 sts, P2tog, P2.

Rep last 2 rows 3 [2: 2: 2: 2: 2] times more.

22 [26: 27: 29: 30: 31] sts.

Next row (RS): K3, K2tog, patt to end.

Next row: Patt.

Next row: K2, K2tog, patt to end.

Next row: Patt.

Rep last 4 rows 1 [2: 3: 3: 3: 3] times more, then first 2 [2: 0: 0: 2: 2] of these rows again, ending with RS facing for next row.

17 [19: 19: 21: 21: 22] sts.

Shape front neck

Next row (RS): K2 [2: 3: 3: 2: 2], K2tog, patt 5 [5: 4: 6: 7: 9] sts and turn, leaving rem 8 [10: 10: 10: 10: 9] sts on a holder (for neckband). 8 [8: 8: 10: 10: 12] sts.

Next row: P2tog, P to end.

Sizes 0-3 and 3-6 months

Next row (RS): K3, (K2tog) twice.

Next row: P2tog, P3. 4 sts.

Sizes 6-9 months only

Next row (RS): K2, K2tog, K1, K2tog.

Next row: P2tog, P3. 4 sts.

Size 9-12 months only

Next row (RS): K2, K2tog, patt 3 sts, K2tog.

Next row: P2tog, P5.

Next row: K3, sl 1, K2tog, pssso. 4 sts.

Next row: P4.

Size 12-18 months only

Next row (RS): K3, K2tog, patt 2 sts, K2tog.

Next row: P2tog, P5.

Next row: K2, (K2tog) twice. 4 sts.

Next row: P4.

Size 2 years only

Next row (RS): K3, K2tog, patt 4 sts, K2tog.

Next row: P2tog, P7.

Next row: (K2, K2tog) twice.

Next row: P6.

Next row: K3, sl 1, K2tog, pssso. 4 sts.

Next row: P4.

All sizes

Next row (RS): K1, sl 1, K2tog, pssso.

Next row: P2.

Next row: K2tog and fasten off.

RIGHT FRONT

Work as given for left front to **.

Beg and ending rows as indicated and repeating the 20 row patt repeat throughout, now place patt from chart as follows:

Row 1 (RS): K3, yfwd (to make a buttonhole), K2, work rem 32 [34: 35: 37: 38: 39] sts as row 1 of chart.

Row 2: Work first 32 [34: 35: 37: 38: 39] sts as row 2 of chart, P1, P2tog (to dec extra st made by buttonhole), K3.

These 2 rows set the sts (front opening edge 3 sts in g st, next 2 sts in st st and rem sts in patt from chart) and make first buttonhole.

Working 12 [14: 12: 14: 12: 14] rows between each **pair** of buttonhole rows and keeping sts correct as now set throughout, complete to match left front, making a further 3 [3: 4: 4: 5: 5] buttonholes and working first row of neck shaping as follows:

Shape front neck

Next row (RS): K8 [10: 10: 10: 10: 9] and slip these sts onto a holder (for neckband), patt to last 4 [4: 5: 5: 4: 4] sts, sl 1, K1, pssso, K2 [2: 3: 3: 2: 2]. 8 [8: 8: 10: 10: 12] sts.

SLEEVES

Using 2¼mm (US 1) needles and yarn B work picot cast-on as follows: cast on 5 sts, cast off 2 sts, slip st on right needle back onto left needle, *cast on 4 sts, cast off 2 sts, slip st on right needle back onto left needle, rep from * until there are 31 [35: 35: 37: 37: 41] sts on left needle, cast on 2 sts. 33 [37: 37: 39: 39: 43] sts.

Break off yarn B and join in yarn A.

Row 1 (RS): Knit.

Change to 3mm (US 2/3) needles.

Work in g st for a further 3 rows, ending with RS facing for next row.

Beg and ending rows as indicated, cont in patt from chart as follows:

Inc 1 st at each end of 3rd [7th: 5th: 7th: 7th: 9th] and every foll 6th [8th: 8th: 8th: 10th] row to 45 [45: 49: 45: 49: 47] sts, then on every foll - [10th: -: 10th: 10th: 12th] row until there are - [47: -: 51: 53: 55] sts, taking inc sts into patt.

Cont straight until sleeve meas 13 [15: 17: 19: 21: 23.5] cm, ending with RS facing for next row.

Shape raglan

Keeping patt correct, cast off 3 sts at beg of next 2 rows. 39 [41: 43: 45: 47: 49] sts.

Next row (RS): K3, K2tog, patt to last 5 sts, sl 1, K1, pssso, K3.

Next row: P2, P2tog tbl, P to last 4 sts, P2tog, P2.

Rep last 2 rows once more.

31 [33: 35: 37: 39: 41] sts.

Next row (RS): K3, K2tog, patt to last 5 sts, sl 1, K1, pssso, K3.

Next row: Purl.

Next row: K2, K2tog, patt to last 4 sts, sl 1, K1, pssso, K2.

Next row: Purl.

Rep last 4 rows 4 [4: 5: 5: 6: 6] times more, then first 0 [2: 0: 2: 0: 2] of these rows again, ending with RS facing for next row. 11 sts.

Break yarn and leave sts on a holder (for neckband).

MAKING UP

Press as described on the information page.

Join all raglan seams using back stitch, or mattress stitch if preferred.

Neckband

With RS facing, using 2¼mm (US 1) needles and yarn A, slip 8 [10: 10: 10: 10: 9] sts from right front holder onto right needle, rejoin yarn and pick up and knit 5 [5: 5: 7: 7: 9] sts up right side of front neck, work across 11 sts on right sleeve holder as follows: K2tog, K7, sl 1, K1, pssso, work across 23 [27: 27: 29: 29: 29] sts on back holder as follows: K2tog, K to last 2 sts, sl 1, K1, pssso, work across 11 sts on left sleeve holder as follows: K2tog, K7, sl 1, K1, pssso, pick up and knit 5 [5: 5: 7: 7: 9] sts down left side of front neck, then K across 8 [10: 10: 10: 10: 9] sts on left front holder. 65 [73: 73: 79: 79: 81] sts.

Work in g st for 3 rows, ending with RS facing for next row.

Break off yarn A and join in yarn B.

Next row (RS): Knit.

Cast off knitwise (on **WS**).

See information page for finishing instructions.

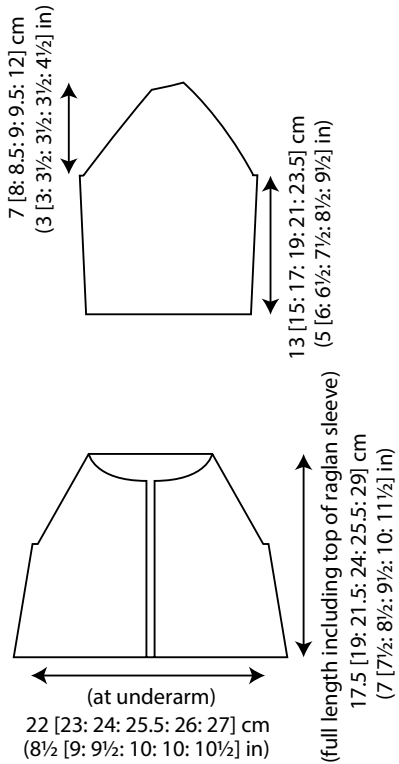

Key

- K on RS, P on WS
- K2tog
- yfwd
- sl 1, K1, pss0

